



Cambridge O Level

PHYSICS

5054/31

Paper 3 Practical Test

May/June 2021

CONFIDENTIAL INSTRUCTIONS



This document gives details of how to prepare for and administer the practical exam.

The information in this document and the identity of any materials supplied by Cambridge International are confidential and must NOT reach candidates either directly or indirectly.

The supervisor must complete the report at the end of this document and return it with the scripts.

INSTRUCTIONS

- If you have any queries regarding these confidential instructions, contact Cambridge International stating the centre number, the syllabus and component number and the nature of the query.
email info@cambridgeinternational.org
phone +44 1223 553554

This document has **12** pages.

General information about practical exams

Centres must follow the guidance on science practical exams given in the *Cambridge Handbook*.

Safety

Supervisors must follow national and local regulations relating to safety and first aid.

Only those procedures described in the question paper should be attempted.

Supervisors must inform candidates that materials and apparatus used in the exam should be treated with caution. Suitable eye protection should be used where necessary.

The following hazard codes are used in these confidential instructions, where relevant:

C	corrosive	MH	moderate hazard
HH	health hazard	T	acutely toxic
F	flammable	O	oxidising
N	hazardous to the aquatic environment		

Hazard data sheets relating to substances used in this exam should be available from your chemical supplier.

Before the exam

- The packets containing the question papers must **not** be opened before the exam.
- It is assumed that standard school laboratory facilities, as indicated in the *Guide to Planning Practical Science*, will be available.
- Spare materials and apparatus for the tasks set must be available for candidates, if required.

During the exam

- It must be made clear to candidates at the start of the exam that they may request spare materials and apparatus for the tasks set.
- Where specified, the supervisor **must** perform the experiments and record the results as instructed. This must be done **out of sight** of the candidates, using the same materials and apparatus as the candidates.
- Any assistance provided to candidates must be recorded in the supervisor's report.
- If any materials or apparatus need to be replaced, for example, in the event of breakage or loss, this must be recorded in the supervisor's report.

After the exam

- The supervisor must complete a report for each practical session held and each laboratory used.
- Each packet of scripts returned to Cambridge International must contain the following items:
 - the scripts of the candidates specified on the bar code label provided
 - the supervisor's results relevant to these candidates
 - the supervisor's reports relevant to these candidates
 - seating plans for each practical session, referring to each candidate by candidate number
 - the attendance register.

Specific information for this practical exam

Number of sets of apparatus

In addition to a few spare sets, the minimum number of sets of apparatus to be provided should be sufficient to enable candidates to spend 20 minutes with the apparatus for each of Questions 1, 2 and 3, and one hour with the apparatus for Question 4. The order in which candidates answer the questions will be determined by the supervisor. Candidates may spend one hour circulating around Questions 1, 2 and 3, followed by an hour on Question 4, or vice versa.

It is assumed that candidates will supply their own calculator and geometrical instruments, such as a set square, 0° to 180° protractor, pair of compasses and 30 cm ruler. Candidates should be advised in advance that they may, if they wish, use wrist-watches with stop-watch facilities, providing that such wrist-watches afford the required precision.

Question 1

Items to be supplied by the Centre (per set of apparatus, unless otherwise specified):

- ray box and slit (see Note 1)
- rectangular transparent block (see Note 2)
- ruler with mm divisions
- protractor
- adhesive putty (Blu Tack, Patafix or similar).

Notes

1. If a ray box with slit is unavailable, the slit plate should be cut from a piece of rigid card into a rectangle of length 80 mm and width 50 mm. A slit of width 1.0 mm and length 25 mm should be cut into the card at 25 mm as shown in Fig. 1.1.

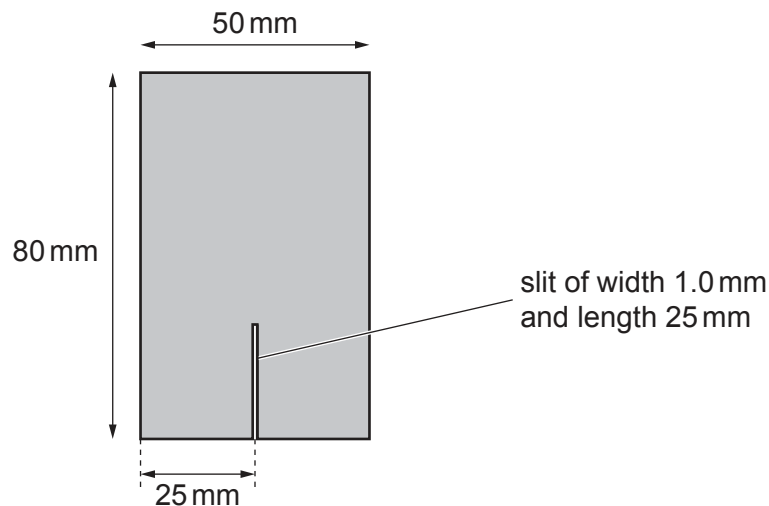

Fig. 1.1

The slit should be illuminated by a small torch lamp of approximate diameter 1 cm, 2.5V, 250mA, filament indicator lamp, clear e.g. RS106-313 placed in a lamp holder e.g. RS171-2603. The lamp holder must be fixed to the bench with a piece of adhesive putty and tilted as shown in Fig. 1.2.

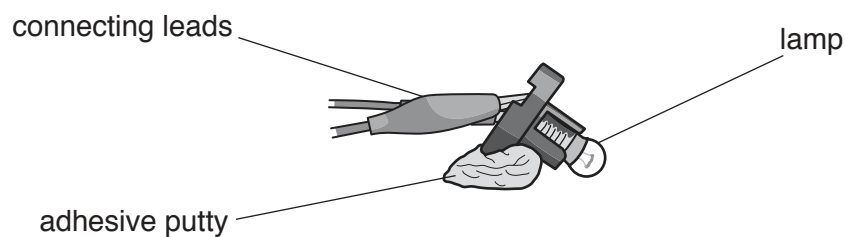

Fig. 1.2

Pieces of adhesive putty should be fixed to the bottom corners of the slit plate as shown in Fig. 1.3.

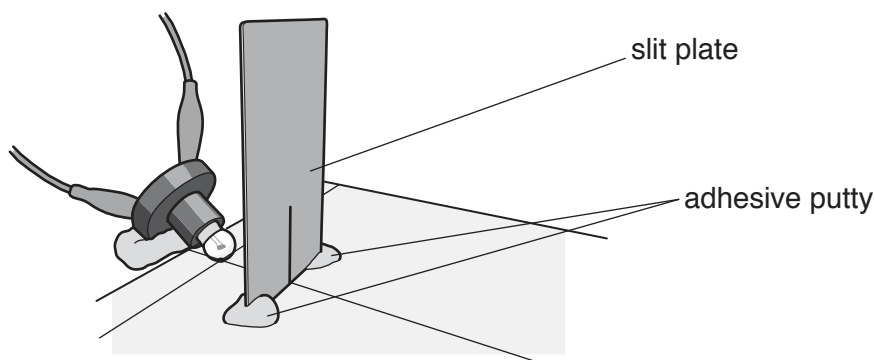

Fig. 1.3

A power supply with a potential difference of 3.0V is sufficient to power the lamp at a suitable brightness. The experiment must be performed in a darkened part of the laboratory.

The following are suitable power sources:

- two 1.5V dry cells in suitable holders connected in series
 - three 1.2V rechargeable cells in suitable holders connected in series
 - d.c. power supply of 3.0V. If a variable power supply is used the supervisor must ensure that the candidates cannot alter the output voltage.
2. A transparent acrylic, glass or perspex block with approximate dimensions 110 mm × 70 mm × 20 mm is suitable. A smaller block with approximate dimensions 75 mm × 50 mm × 18 mm is also suitable.

Action at changeover

The supervisor should ensure that the power supply is still capable of illuminating the lamp at a suitable brightness and then switched off.

Information required by Examiners

Sample set of numerical results, clearly marked 'supervisor's results', obtained out of sight of the candidates.

Question 2

Items to be supplied by the Centre (per set of apparatus, unless otherwise specified)

- power supply (see Note 1)
- light-dependent resistor (LDR) (see Note 2)
- a piece of card labelled with an 'X' (see Note 2)
- a piece of card labelled with a 'Y'
- light-emitting diode (LED) (see Note 3)
- ammeter capable of measuring a current up to 1.00A to a precision of 0.01A or better – an analogue or digital meter is suitable. The candidate needs to be able to see movement on the ammeter when the LDR is covered over. A range of 0–200 mA is ideal.
- voltmeter capable of measuring a potential difference of 5.0V to a precision of 0.1 V or better – an analogue or digital meter is suitable
- connecting leads and crocodile clips (see Note 4)
- switch or plug key.

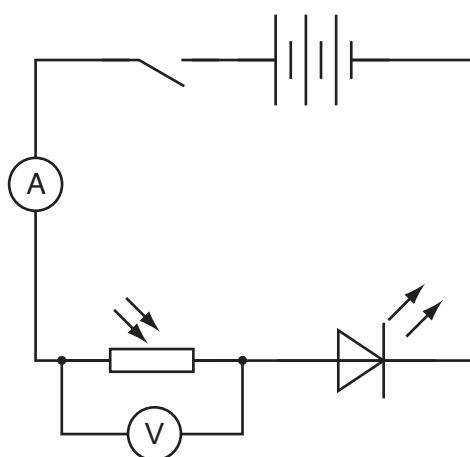

Fig. 2.1

Notes

1. The power supply should be made from three 1.5V dry cells in a suitable holder connected in series.
2. A suitable LDR is the Silonex NORPS-12. The RS component code is RS914-6714. The LDR must be placed on a piece of card labelled X.
3. A suitable LED is the Kingbright L-793SRD-D 8 mm Super Bright Red LED 400 mcd. The RS component code is RS 229-2368. The LED must be placed on a piece of card labelled Y.

Any LED and LDR combination may be used so long as the LED is lit when the LDR is uncovered. It may be necessary to provide the LDR with suitable illumination.

4. The supervisor should set up the circuit shown in Fig. 2.1. Short connecting leads should be used so that there is no overlapping and the layout of the circuit is clearly visible to the candidate.

Action at changeover

The supervisor must ensure that the circuit is in the configuration shown in Fig. 2.1 with the switch open. The LDR should be on card X and the LED should be on card Y.

Information required by Examiners

Sample set of numerical results, clearly marked 'supervisor's results', obtained out of sight of the candidates.

Question 3

Items to be supplied by the Centre (per set of apparatus, unless otherwise specified)

- twine (see Note 1).
- pulley with a diameter of 50 mm.
- two 100 g mass hangers (see Note 2).
- stand, boss and clamp (see Note 3).
- piece of modelling clay (see Note 4).
- metre rule.
- stop-watch reading to 0.1 s or better.
- set square.
- a heavy weight or G-Clamp (see Note 5).

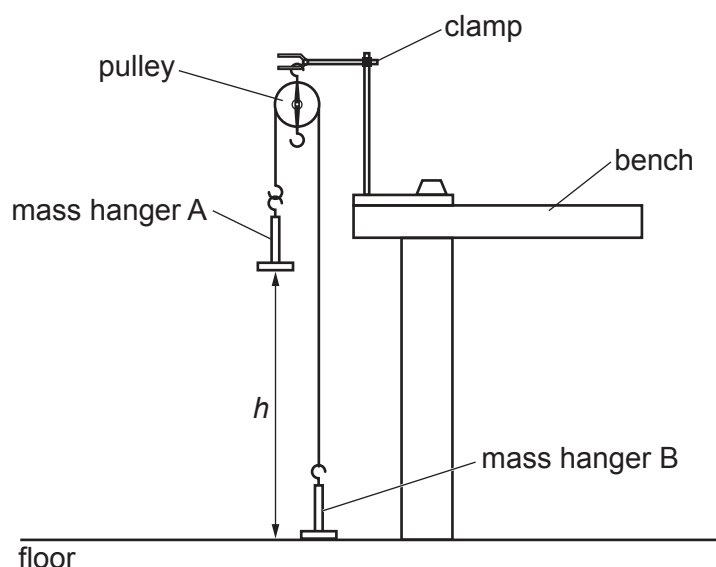

Fig. 3.1

Notes

1. A length of 2 mm diameter twine or string should be cut and loops tied at each end. The total length of the twine will be approximately 145 cm. With the mass hangers placed on the ends of the loops as shown in Fig. 3.1, the position of the clamp should be adjusted so that the base of mass hanger A is between 70 cm and 80 cm above the floor and mass hanger B is resting on the floor.
2. The mass hangers must be narrow enough so that they are able to pass each other without colliding with each other or the bench.
3. The stand must be long enough for candidates to adjust the position of the clamp so that the height h of the base of mass hanger A can be raised to more than 101 cm with mass hanger B still at rest on the floor.

4. A piece of modelling clay of approximate mass 7–12 grams should be rolled into a ball and placed on a piece of card near the apparatus. Adhesive putty (Blu Tack, Patafix or similar) is also suitable. The precise mass of the modelling clay should be adjusted so that when it is placed on mass hanger A, the mass hanger is able to descend slowly towards the floor, taking about 5 s to fall through 1 m. You may have to give the mass hanger a gentle push downwards to start the movement. Write the mass in grams of the modelling clay on the piece of card.
5. To prevent the stand toppling over it should be secured to bench by placing a heavy weight on the base or by fastening it with a G-clamp.

Action at changeover

The supervisor must ensure that the apparatus is in the configuration shown in Fig. 3.1 with the piece of modelling clay or adhesive putty rolled into a ball on top of the piece of card and the position of the clamp on the stand lowered so that h is between 70 and 80 cm.

Information required by Examiners

Sample set of numerical results, clearly marked 'supervisor's results', obtained out of sight of the candidates.

Question 4

Items to be supplied by the Centre (per set of apparatus, unless otherwise specified)

- glass ball (see Note 1)
- two 1.0 metre rules to make a track (see Note 2)
- modelling clay and adhesive putty (Blu Tack, Patafix or similar) (see Note 2)
- half-metre rule
- stop-watch reading to 0.1 s or better.

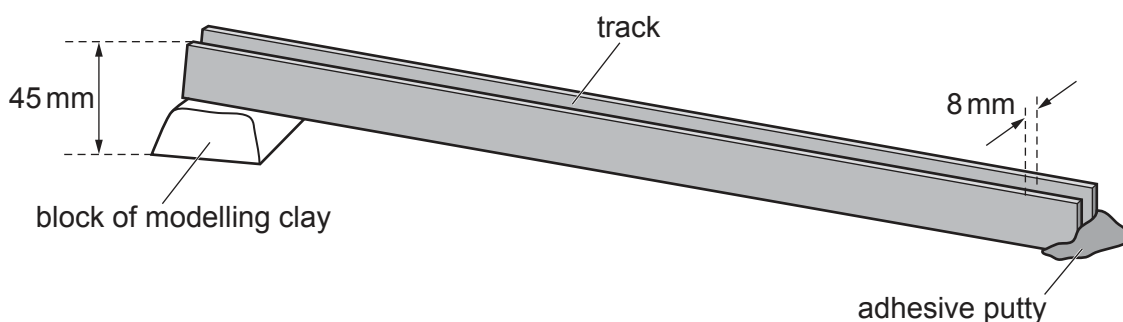

Fig. 4.1

Notes

1. A glass ball of approximate diameter 15 mm should be used. A suitable glass ball is one that is commonly used in the children's game 'marbles'.
2. The track is formed from two metre rules in parallel 8 mm apart. The scale must face towards the candidate. The top end of the track is pressed firmly into a large block of modelling clay so that the highest point is 45 mm above the bench as shown in Fig. 4.1. The track must be fixed at the bottom end using adhesive putty to maintain the gap of 8 mm and to prevent the track from moving on the bench. A piece of cloth should be placed on the bench after the end of the track to catch the ball.

The 100 cm marks on the rules must be at the top of the track

Action at changeover

The supervisor must ensure that the apparatus is in the configuration shown in Fig. 4.1

Information required by Examiners

Sample set of numerical results, clearly marked 'supervisor's results', obtained out of sight of the candidates.

Permission to reproduce items where third-party owned material protected by copyright is included has been sought and cleared where possible. Every reasonable effort has been made by the publisher (UCLES) to trace copyright holders, but if any items requiring clearance have unwittingly been included, the publisher will be pleased to make amends at the earliest possible opportunity.

To avoid the issue of disclosure of answer-related information to candidates, all copyright acknowledgements are reproduced online in the Cambridge Assessment International Education Copyright Acknowledgements Booklet. This is produced for each series of examinations and is freely available to download at www.cambridgeinternational.org after the live examination series.

Cambridge Assessment International Education is part of the Cambridge Assessment Group. Cambridge Assessment is the brand name of the University of Cambridge Local Examinations Syndicate (UCLES), which itself is a department of the University of Cambridge.

Supervisor's report

Syllabus and component number

				/		
--	--	--	--	---	--	--

Centre number

--	--	--	--	--

Centre name

Time of the practical session

Laboratory name/number

Give details of any difficulties experienced by the centre or by candidates (include the relevant candidate names and candidate numbers).

You must include:

- any difficulties experienced by the centre in the preparation of materials
- any difficulties experienced by candidates, e.g. due to faulty materials or apparatus
- any specific assistance given to candidates.

Space for supervisor to record results, if relevant, e.g. temperature of the laboratory; results for Question 1.

Declaration

- 1 Each packet that I am returning to Cambridge International contains all of the following items:
 - the scripts of the candidates specified on the bar code label provided
 - the supervisor's results relevant to these candidates
 - the supervisor's reports relevant to these candidates
 - seating plans for each practical session, referring to each candidate by candidate number
 - the attendance register.
- 2 Where the practical exam has taken place in more than one practical session, I have clearly labelled the supervisor's results, supervisor's reports and seating plans with the time and laboratory name/number for each practical session.
- 3 I have included details of difficulties relating to each practical session experienced by the centre or by candidates.
- 4 I have reported any other adverse circumstances affecting candidates, e.g. illness, bereavement or temporary injury, directly to Cambridge International on a *special consideration form*.

Signed (supervisor)

Name (in block capitals)